

Operating instructions

ASI - TV Transmodulator

ASI → ATV (AM)



Contents

| | |
|---|----|
| 1. Safety and operating instructions | 2 |
| 2. Device variants | 2 |
| 3. General | 2 |
| 4. Front view | 3 |
| 5. Function description | 3 |
| 6. Adjustments | 3 |
| 6.1 Adjustment with the Headend Controller | 3 |
| 6.2 Adjustment with the PC / laptop | 3 |
| 7. Meaning of LED signals | 4 |
| 7.1 LED`s for the ASI ports | 4 |
| 7.2 LED`s on front panel | 4 |
| 8. Optional hardware variants | 4 |
| 8.1 IF interface | 4 |
| 8.2 Additional A/V monitor outputs | 5 |
| 9. Programming by Web server | 6 |
| 9.1 Main menu | 6 |
| 9.2 Software options | 6 |
| 9.3 Loading the programme list | 7 |
| 9.4 Extended settings | 8 |
| 9.5 Manual settings | 9 |
| 9.6 Factory settings | 9 |
| 9.7 Status of device | 10 |
| 10. Manual menu control at the Headend Controller | 11 |
| 11. Trap messages | 11 |
| 12. Block diagram | 12 |
| 13. Head end BUS structure | 12 |
| 14. Example of use | 13 |
| 15. Technical data .. | 13 |
| 16. Glossary | 14 |
| 17. Bibliography | 14 |
| 18. History | 14 |



ATB 19x
Part N°: 9848.xx

1. Safety and operating instructions



When assembling, starting-up and adjusting the modules, it is necessary to consider the system specific references in the manual instruction!



The modules may only be installed and started up by authorized technical personnel!



When assembling the modules into the receiving points, the adherence of the EMC regulations is to be secured!



The assembly and wiring have to be done without voltage!



All active modules may only be operated with the Headend Controller HCB x00 or Bus Extender BEB x00!



The main voltage and the operating voltage of the modules working by DC have to be in compliance to the operating parameters described in the technical data.



With all work the defaults of the DIN EN 50083 have to be considered! Especially the safetyrelevant execution of the DIN EN 60728-11 [2] is necessary!

2. Device variants

| | | |
|---------|---------|--------------------------------------|
| ATB 191 | 9848.01 | ASI → ATV (AM) standard B/G |
| ATB 191 | 9848.08 | ASI → ATV (AM), A/V standard B/G |
| ATB 191 | 9848.09 | ASI → IFI → ATV (AM) standard B/G |
| ATB 192 | 9848.21 | ASI → ATV (AM) standard D/K 1* |
| ATB 192 | 9848.22 | ASI → ATV (AM) standard D/K 2* |
| ATB 192 | 9848.24 | ASI → ATV (AM), A/V standard D/K 2* |
| ATB 192 | 9848.25 | ASI → ATV (AM), A/V standard D/K 1* |
| ATB 192 | 9848.28 | ASI → IFI → ATV (AM) standard D/K 2* |
| ATB 192 | 9848.29 | ASI → IFI → ATV (AM) standard D/K 1* |

* D/K 1: standard D/K with sound carrier 6,5 MHz and 6,25 MHz
D/K 2: standard D/K with sound carrier 6,5 MHz and 5,74 MHz

Minimum software requirements for HCB x00:

9650.03: version 2.34**
9650.04/.05: version 3.18**
9652.01: version 3.23**

**) Updates: www.blankom.de

3. General

The ATB 19x ASI-TV transmodulators are components of the B-LINE head end system which has been designed as a complete package for medium-sized distribution networks. They are components which select a programme from the ASI transport stream and convert it into an analogue cable TV channel. All the components are programmed via a single central control unit and thereafter each component will function independently. The status of the modules are displayed via LED's (see chapter 7.2 „LED`s on front panel“).

4. Front view

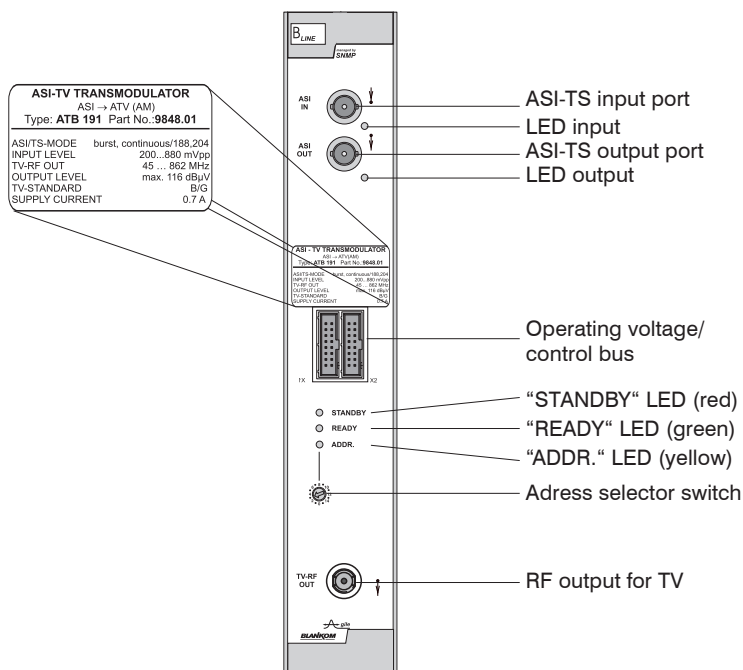

managed by
SNMP

5. Function description

With this transmodulator, the digital ASI signal is decoded and then transferred into a serial data stream. Next, that data stream is parallelised and fed into a FIFO system. The timing of this data input will in all cases be calculated from how full the FIFO system is and adapted to the general data input rate. The regeneration system for the transport stream SPI protocol follows at the FIFO system output, and at the same time, recognition of the transport stream being correct is ensured. It is at this level that the transport stream can be edited. From the transport stream, the succeeding MPEG decoder selects a programme and generates an analogue video signal and a digital audio signal. In the D/A converter which comes next; these two are converted into two analogue audio channels. The analogue signals are fed into separate modulators and then aggregated in the IF (intermediate frequency) position. Then the IF filtering takes place, and after that the production in the desired output channel. The fact that mixers are used which can accommodate a high output, also fractional N-PLLs, guarantees high-quality transmission. There is a free choice of frequency in the output channel from 45 to 862 MHz. On the output side, the modulator does not leak to adjacent channels. If the output level changes, the red LED will flash. Every time the level or frequency figures are programmed, automatic measurement of the reference level takes place; this function will, however, not start until 100 seconds have elapsed after start-up of the system. When the output load changes (perhaps because the output cable is disconnected), a warning and display item for a level fault may also appear. When the fault has been identified, the appropriate SNMP Trap message will be sent. Use of this function is optional. By activation of the respective software option the services like test lines, the flash of subtitles and BISS decryption can be used. Supported are the BISS mode 1 and the BISS mode E with input of the necessary Injected ID, but not the BISS mode E with the additional input of the optional Buried ID.

6. Adjustments

6.1 Adjustment with the Headend Controller

- Adjustment of the addresses at the Bus Extender BEB x00 and at the modules
- Activation of the programming mode of each module by selecting the line (BEB x00) and the module position (01... 15) at the Headend Controller (HCB x00)
 - yellow LED will be lit up til the beginning of the parameter adjustment
- Adjustment of the ATB 19x parameter (see chapter 10) → green LED is lit up
- After the programming the ATB 19x will be automatically switched into the operating
 - yellow LED lights up briefly / green LED is lit up

6.2 Adjustment with the PC / Laptop

- Condition for the remote programming is an "online - connection" after IP - standard and an ethernet connection at the PC / Laptop
- Adjustment of the line / position addresses at the Bus Extender BEB x00 as well as at the modules
- At the Headend Controller HCB x00 IP - address input (e.g. 192.168.001.001)
- For "direct connection" between a PC and HCB x00 use a crossed patch cable (RJ 45)
- For connection over a deviation use an uncrossed patch cable
- HTML - browser start-up and put in IP - address as target address
- If connected correctly the HTML - control surface at the PC will open up and a blue LED (LINK) at the HCB x00 will be lit up).
- All adjustment of the modules are specified at the control surface.

The manual instructions of the Headend Controller HCB x00 and the Bus Extender BEB x00 have to be considered!

7. Meaning of LED signals

7.1 LED`s for the ASI ports

| Colour | Status | Meaning of display |
|--------|-------------------------|---|
| green | permanently illuminated | ASI channel has been configured as input |
| | flashing | no ASI signal |
| yellow | permanently illuminated | ASI channel has been configured as output |
| | flashing | no ASI signal |

7.2 LED`s on front panel

| Designation (Colour) | Status | Meaning of display |
|----------------------|-------------------------|---|
| STANDBY (red) | permanently illuminated | Component is on standby |
| | flashing | Component faulty (hardware) or level fault |
| READY (green) | permanently illuminated | Component working, everything ok |
| | flashing | error warnings, depending on signal: - ASI without sync (e.g. when there is no input signal) - service settings are not valid - service is decrypted |
| ADDR. (yellow) | illuminated or flashing | remote control making contact / data being exchanged |

8. Optional hardware variants

8.1 IF interface

The IF interface is an optional additional function/equipment for the modules of the head end system B - LINE. The IF - interface separates the internal analogue TV- IF - signal - path and enables the lead out, the external processing and the re-feeding of the IF- signal into the module. The connection sockets (type SMA) are located at the backside of the individual modules. The impedance is 75 Ohm. The following device variants are equipped with an IF interface:

9848.09

9848.28

9848.29

View (back side of component)

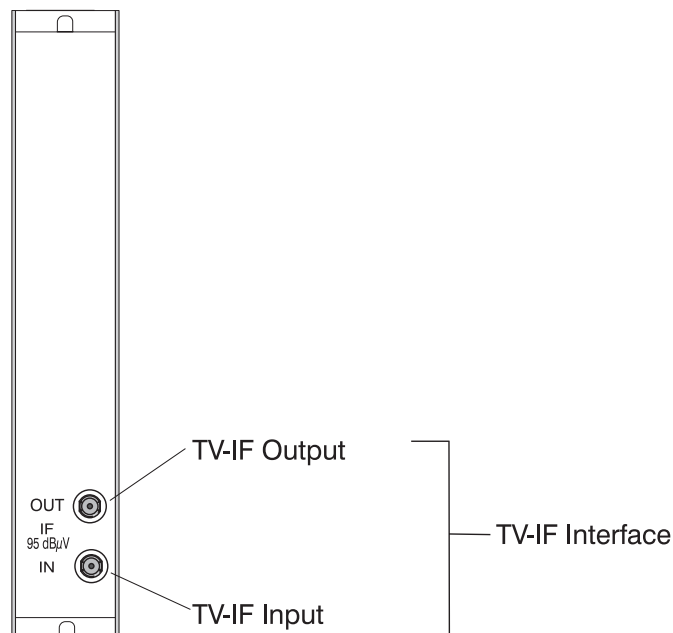

Function description

The analogue TV - IF signal (picture and sound carrier) will be split after the main selection (SAW filter) and transported to the IF - output socket. The processed signal will go from the IF input socket over an absorption- and adjustment unit directly to the upward mixer. It has to be considered that no other channel selective filter stages are located in the input signal path and no level adjustments and/or level control possibilities are available..

For the normal function of the interface, the conditions defined in the manual instructions have to be considered!

Operating instructions

1. The IF input level may only vary ± 1 dB from the IF output level (95 dB μ V). External IF modules may not change the level of the signal and/or have to provide the necessary level at the output!
2. The external IF module, which is used for the processing and/or feeding of the IF signal, may not produce any spurious, which fall below the necessary signal-to-noise ratio (>60 dB). If necessary, an additional IF filter has to be connected between the output of the external module and the IF interface input..
3. If a module with IF interface is mounted to the wall, the usage of SMA angle plugs for the interface side of the connection cable is recommended. The cables have to be screwed onto the interface socket before installing the module.
4. The connection cables and the plug connectors for the external IF modules, as well as their IF connections must have an impedance of 75 ohm (e.g. RG 179 B/U with 75 ohm - BNC - plug connections).
5. To bypass the IF interfaces, the interface sockets have to be connected with a short cable (jumper). An internal module bypass (e.g. by a jumper) is not possible!

Technical data

| | |
|--|---------------------|
| Output / input frequency (picture carrier analogue TV) | 38,9 MHz |
| Frequency range | 32,15 ... 40,15 MHz |
| Output / input level | 95 dB μ V |
| Impedance | 75 Ω |
| Connector | 2 x SMA socket |
| IF decoupling | ≥ 80 dB |

8.2 Additional A/V monitor outputs

These options have in comparison with the relevant basic variant a video output and two audio outputs for monitoring. The additional outputs are located in the upper part of the front side and are implemented as MCX sockets.

The following device variants are equipped with additional A/V outputs:

- 9848.08
- 9848.24
- 9848.25

Front view

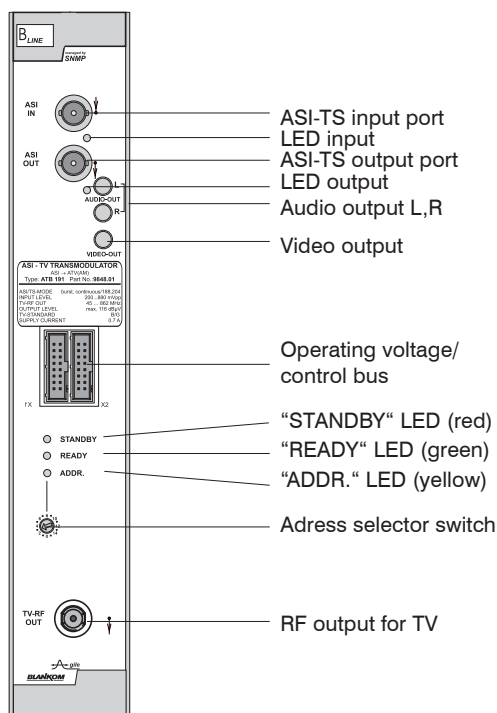

Technical data

| | |
|--------------|-------------------------------|
| Audio output | 0,7 V _{eff} at 10 kΩ |
| Connector | MCX socket |
| Video output | 1 V _{ss} at 75 Ω |
| Connector | MCX socket |

9. Programming by Web server*

9.1 Main menu

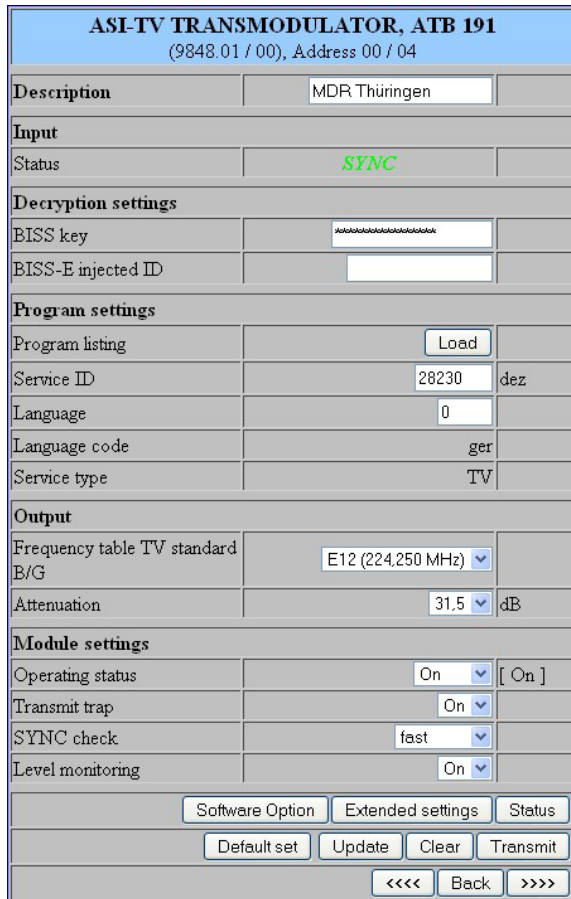

Name of device, item number, address in head end

Description Name of programme (max. 30 characters)
Input display wether **SYNC**hronization or **noSYNC**hronisation with Input
Status

Decryption settings (will only be available if "BISS decryption" option is on)
BISS key input of the 12-digit code in BISS mode 1 or of the 16-digit code in BISS mode E
BISS-E injected ID input of the 14-digit code in BISS mode E, no input in BISS mode 1!

Program settings
Program listing see Menu 2
Service ID freely selectable (0...65535)
Language freely selectable (0...255)
Language code shows the code for the language selected
Service type shows the type of service selected (TV, radio)

Output
Frequency table channel selection:
standard B/G channel 2..69
standard D/K channel R1.. 69
Attenuation adjustment range 0 ... 31.5 dB

Module settings
Operating status selection: On, Off, Reset
Transmit trap On/Off, if SNMP option in HCB x00 enabled, otherwise "locked" display
SYNC check checks SYNC at input port. selection: fast, normal, slow
Level monitoring at output port. selection: On, Off

Routing to the appropriate adjustment menu:
Software option see menu 1
Extended settings see menu 3
Status see menu 6
Default set see menu 5

9.2 Software option (menu 1)

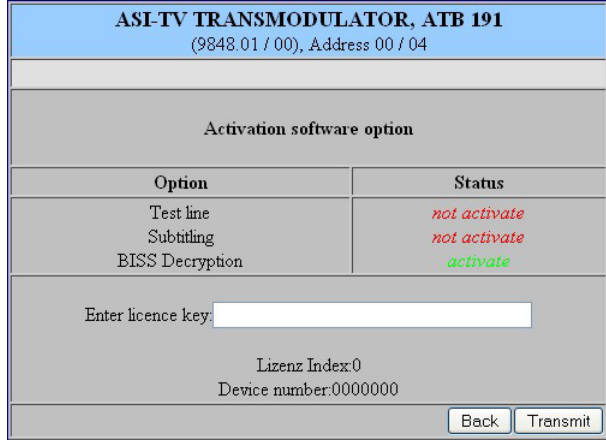

Name of device, item number, address in head end

Dialogue for entering code to activate the "test line" (CKB 101), "subtitling" (CKB 102) and "BISS decryption" (CKB 104) software options. When the page is called up, the current state of activation for the relevant option will be displayed.

* Further details on this are to be found in the HCB manual

9.3 Loading the programme list (menu 2)

ASI-TV TRANSMODULATOR, ATB 191
 (9848.01 / 00), Address 00 / 04

Program listing

| Program name | Status | Service type | Service-ID | Audio Language | Subtitle language | Selection |
|------------------|--------|--------------|------------|----------------|-------------------|------------------------------------|
| rbb Brandenburg | free | TV | 28205 | 0;ger | missing | <input type="button" value="Set"/> |
| rbb Berlin | free | TV | 28206 | 0;ger | missing | <input type="button" value="Set"/> |
| ARD-Online-Kanal | free | TV | 28218 | 0;- ▾ | missing | <input type="button" value="Set"/> |
| ARD-TEST-1 | free | TV | 28221 | 0;--- | missing | <input type="button" value="Set"/> |
| ARD-TEST-2 | free | TV | 28222 | 0;ger | missing | <input type="button" value="Set"/> |
| NDR FS MV | free | TV | 28224 | 0;ger ▾ | missing | <input type="button" value="Set"/> |
| NDR FS HH | free | TV | 28225 | 0;ger ▾ | missing | <input type="button" value="Set"/> |
| NDR FS NDS | free | TV | 28226 | 0;ger ▾ | missing | <input type="button" value="Set"/> |
| NDR FS SH | free | TV | 28227 | 0;ger ▾ | missing | <input type="button" value="Set"/> |
| MDR Sachsen | free | TV | 28228 | 0;ger ▾ | missing | <input type="button" value="Set"/> |
| MDR S-Anhalt | free | TV | 28229 | 0;ger ▾ | missing | <input type="button" value="Set"/> |
| MDR Thüringen | free | TV | 28230 | 0;ger ▾ | missing | <input type="button" value="Set"/> |
| SWR Fernsehen RP | free | TV | 28231 | 0;ger | missing | <input type="button" value="Set"/> |

This menu contains a list of all services contained in the data stream. Language selection can take place here if available. Any service is adopted or given new settings by clicking the relevant "Set" button.

9.4 Extended settings (menu 3)

| ASI-TV TRANSMODULATOR, ATB 191 (9848.01 / 00), Address 00 / 04 | |
|--|----------------|
| Video | |
| Video output | On |
| Colour bar | Off |
| Colour system | PAL |
| Video format | letterbox |
| Audio settings | |
| Audio gain | 0 dB |
| Audio mode | auto |
| Output | |
| Sound deviation | 30 kHz |
| Sound carrier2 | On |
| Picture carrier frequency | 224250 kHz |
| VPS settings | |
| CNI code | 0x000 |
| Source audiomode | MPEG |
| Source PIL | A056 (PDC) |
| Complementary data | |
| Teletext | On |
| WSS insertion | On |
| Subtitling | |
| Mode | Off |
| Settings DVB subtitling | |
| DVB language index | 0 |
| DVB language code | --- |
| Use extended ID's | yes |
| Composition Page ID | 0 dez |
| Ancillary Page ID | 0 dez |
| Settings Teletext subtitling | |
| Teletext site | 0 |
| Background | opaque |
| Character mode | auto |
| The following settings are used only in the manual character mode! | |
| Basic character | Latin |
| Supplementary character | Latin |
| National table | standard table |
| Test lines | |
| Line 17 | Off |
| Line 18 | Off |
| Line 330 | Off |
| Line 331 | Off |
| Extended monitoring options | |
| Internal AVsync info | On |
| Manual settings | |
| Update Clear Transmit | |
| Back | |

Name of device, item number, address in head end

Video
Video output selection: On, auto off, auto colour palette bar
Colour bar selection: On, Off
Colour system selection: PAL, SECAM, NTSC
Video format selection: Letterbox, center cut, 1:1, pillarbox, 4:3 vertical cut, 20:9 letterbox

Audio settings
Audio gain adjustment range +6...-20 dB
Audio mode selection: auto, monoL, monoR, stereo, dual, dual invers (2 sound carriers) auto, monoL, monoR, monoL+R (only 1 sound carrier)

Output
Sound deviation selection: 30 kHz (2 sound carriers) 30 kHz, 50 kHz (only 1 sound carrier)
Sound carrier 2 selection: On, Off
Picture carrier frequency frequency input in kHz, automatic rounding up or down to next 10 kHz on adoption

VPS settings
CNI code freely selectable hex. (0x000...0xFFFF)
Source audiomode selection: MPEG, A056(MPEG)
Source PIL selection: A056(PDC), A056, PDC, TimerControlCode

Complementary data
Teletext selection: On, Off
WSS insertion selection: On, Off

Subtitling
(will only be available if "Subtitling" option is on)
Mode Selection: Off, Teletext, DVB

Settings DVB Subtitling
(will only be available if "Subtitling" option is on)
DVB languages index freely selectable (0...255)
DVB language code shows the code for the language selected
Use extended ID's selection: yes, no
Composition Page ID shows the ID (decimal figure)
Ancillary Page ID shows the ID (decimal figure)

Settings Teletext subtitling
(will only be available if "Subtitling" option is on)
Teletext site freely selectable (0...65535)
Background selection: not transparent, semi-transparent, transparent, black transparent
Character mode selection: auto, manual

The following parameters only apply if the manual mode has been selected for the font:

Basic character selection: Latin, Cyrillic-1, Cyrillic-2, Cyrillic-3, Arabic, Greek, Hebrew
Supplementary character selection: Latin, Cyrillic, Arabic, Greek, Hebrew
National table selection: standard table, alternative table, no country code, English, German, Swedish, Italian, French, Spanish, Czech, Rumanian, Polish, Estonian, Latvian, Serbian, Turkish, Danish

Test lines
(will only be available if "Test lines" option is on)
Line 17 a test signal can be sent on all four of these lines, the signal selection is:
Line 18 off, CCIR17, CCIR 18, CCIR 330m,
Line 330 CCIR331, Sinus (x)/x, Ramp
Line 331

Extended monitoring options
Internal AVsync Info display option on status page (menu 6), selection: On, Off

Routing to the appropriate adjustment menu:
Manual settings see menu 4

9.5 Manual settings (menu 4)

| ASI-TV TRANSMODULATOR, ATB 191 (9848.01 / 00), Address 00 / 04 | | |
|--|--------------------------------|-----|
| PCR for current service | | |
| Use PCR PID | <input type="text" value="0"/> | dez |
| Manual PID settings | | |
| PCR-PID | <input type="text" value="0"/> | dez |
| Video-PID | <input type="text" value="0"/> | dez |
| Audio-PID | <input type="text" value="0"/> | dez |
| Teletext-PID | <input type="text" value="0"/> | dez |
| VBI-PID | <input type="text" value="0"/> | dez |
| Subtitle-PID | <input type="text" value="0"/> | dez |
| Composition Page-ID | <input type="text" value="0"/> | dez |
| Ancillary Page-ID | <input type="text" value="0"/> | dez |
| <input type="button" value="Update"/> <input type="button" value="Clear"/> <input type="button" value="Transmit"/> | | |
| <input type="button" value="Back"/> | | |

Name of device, item number, address in head end

PCR for current service

Use PCR PID freely selectable (0...65535))

Manual PID settings

PCR-PID freely selectable (0...65535)
 Video-PID freely selectable (0...65535)
 Audio-PID freely selectable (0...16383)
 Teletext-PID freely selectable (0...65535)
 VBI-PID freely selectable (0...65535)
 Subtitle-PID freely selectable (0...65535)
 Composition Page-ID freely selectable (0...65535)
 Ancillary Page-ID freely selectable (0...65535)

9.6 Factory settings (menu 5)

Default values are set.
Please wait...

When this menu is called up, all the settings made on the EEPROM will be deleted and replaced by the default settings. The modul will go back to these default values. Once the setting process is over, there will be automatic return to the main menu.

9.7 Status of device (menu 6)

| ASI-TV TRANSMODULATOR, ATB 191 (9848.01 / 00), Address 00 / 04 | | |
|---|---|-----|
| ASI input | | |
| Status | SYNC | |
| Information | TS packet size: 188 Byte MPEG data rate: 38.15104 Mbps | |
| MPEG Decoder | | |
| Status | TS: SYNC Audio Decoder: SYNC Video Decoder: SYNC | |
| SysClock | PcrPID,iSync,DPLL/set, ok, 7ppm | |
| AudioSync | AvgDiff,SR,updSync,fill/-24, 1, ok, 3056 | |
| VideoSync | Diff,SR,nUpdSync/1759, 1, 804 | |
| Complementary data | | |
| Current VPS data | PLL= 07.10 07:45 Running Audio= stereo CNI= 0x0DFE | |
| Current WSS data | 4:3 full A056_WSS 0x8 4:3 | |
| Test line insertion | Line 17: Off Line 18: Off Line 330: Off Line 331: Off | |
| Status output | | |
| Signal level | ok | |
| Status PLL 1 / 2 | ok / ok | |
| Sound carrier 1 / 2 | 5,5 / 5,74 | MHz |
| Software versions | | |
| AP Controller | 9848.01-81.01 AP-Controller V1.00 06.10.2008 JH | |
| MPEG | 9611.01-86.01 (Dual) MPEG_CI V1.17 08.09.08 SS | |
| Internal controller | 9199.01-88.01 internal Controller V1.03 06.04.2008 JH | |
| FPGA MC | 9850.02-88.01 FPGA Download Controller V1.35 08.09.2008 MF,PK | |
| FPGA | 9848.01-87.01 ASI Input FPGA V1.02 07.08.2008 WE,MF | |
| Information | | |
| Temperature AP | 29 °C | |
| Device number | 0222128 | |
| Device index | 00 | |
| <input type="button" value="Update"/> <input type="button" value="Back"/> | | |

Name of device, item number, address in head end

ASI input

Status synchronisation status
Information details of TS packet length and MPEG data rate

MPEG Decoder

Status Synchronisation status for the TS and the audio and video decoder

The following will only be displayed if the internal AVsync info option is switched on (see menu 3)

SysClock details of system timing
AudioSync extended details of synchronisation status of the audio decoder
VideoSync extended details of synchronisation status of the video decoder

Complementary data

Current VPS data shows detailed information about current VPS data
Current WSS data shows detailed information about current WSS data

The following will only be displayed if the "test lines" option is switched on:

Test line insertion Shows which test signal is set for the 4 lines

Status output

Signal level Shows status of signal level at output (ok, too high, too low)
Status PLL1/2 Shows whether or not PLL1 (or PLL2) is activated (ok, not ok)
Sound carrier 1/2 Shows frequency of sound carrier 1 or 2

Software versions

Shows the software versions for the controllers as follows:

- Controller of terminals board
- MPEG Controller
- Controller IF converter
- Download controller for FPGA ASI input
- FPGA ASI input

Information

Temperature AP Temperature of terminals board
Device number display of the device number
Device index display of the device index (hardware)

10. Manual menu control at the Headend Controller (HCB x00)

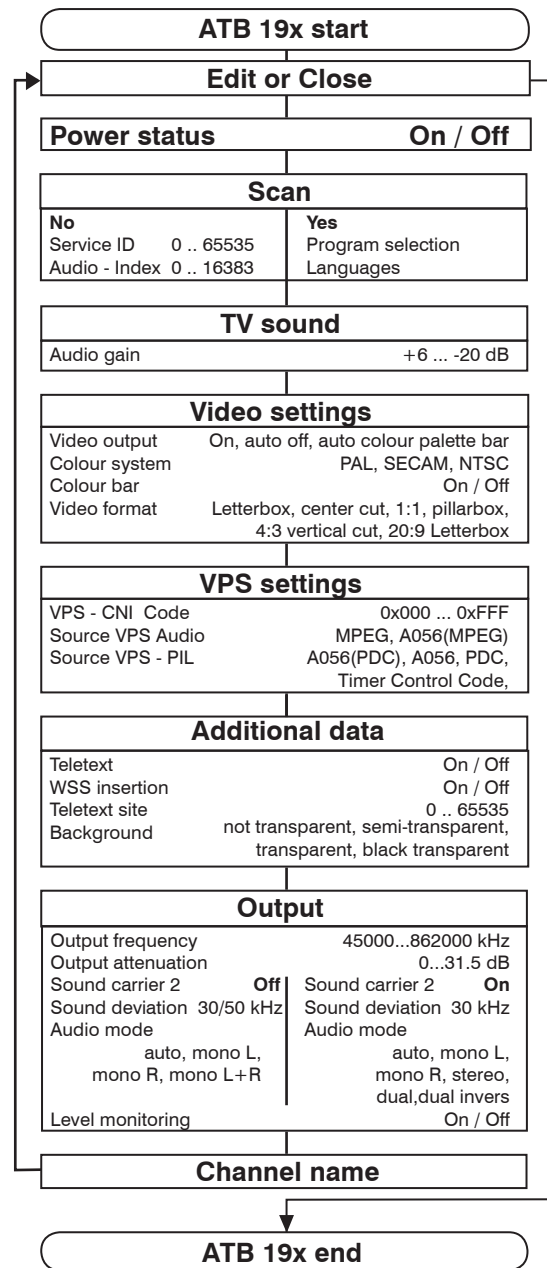

11. Trap messages

| Item | Message | Message Typ | Explanation |
|------|------------------------------|-------------|--|
| 01 | Signal OK | INFORMATION | Component working, everything ok |
| 02 | Input not sync | WARNING | Input not synchronised |
| 03 | MPEG Error | CRITICAL | MPEG error |
| 04 | System reset | WARNING | System has been reset after internal error |
| 05 | MPEG-Decoder not sync | WARNING | MPEG decoder not synchronised |
| 06 | Power fail | CRITICAL | Error in power supply |
| 08 | IIC Error | CRITICAL | Error in IIC or internal hardware |
| 09 | Output Signallevel too small | WARNING | Level of output signal too low |
| 10 | Output Signallevel too large | WARNING | Level of output signal too high |
| 11 | Output Signallevel ok | INFORMATION | Level of output signal ok |
| 12 | PLL error | CRITICAL | PLL at output not activated |

| Item | Message | Message Typ | Explanation |
|------|---------------------|-------------|---------------------------------|
| 13 | Tonmode Mono L+R | INFORMATION | Sound mode set as mono total |
| 14 | Tonmode Mono L | INFORMATION | Sound mode set as mono on left |
| 15 | Tonmode Mono R | INFORMATION | Sound mode set as mono on right |
| 16 | Tonmode Stereo | INFORMATION | Sound mode set as stereo |
| 17 | Tonmode Dual | INFORMATION | Sound mode set as dual |
| 18 | Tonmode Dual invers | INFORMATION | Sound mode set as dual inverse |

12. Block diagram

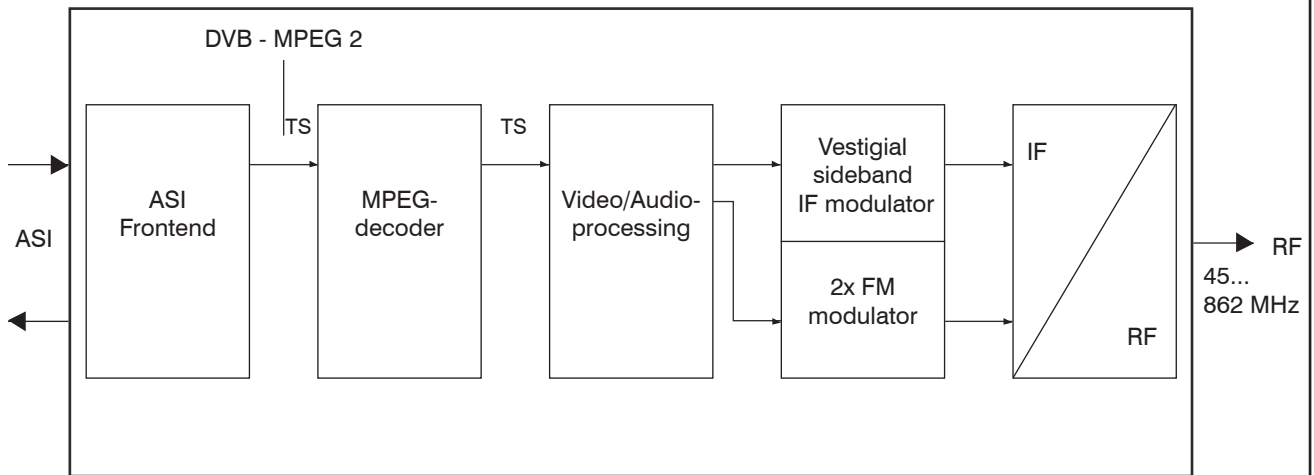

13. Head end BUS structure

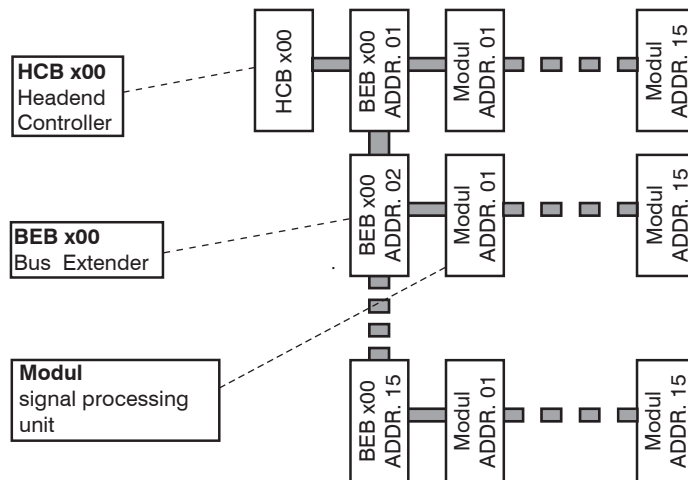

The number of the possible module connections (00 ... 15) to a BEB x00 depends on the total power consumption of this line!

14. Example of use

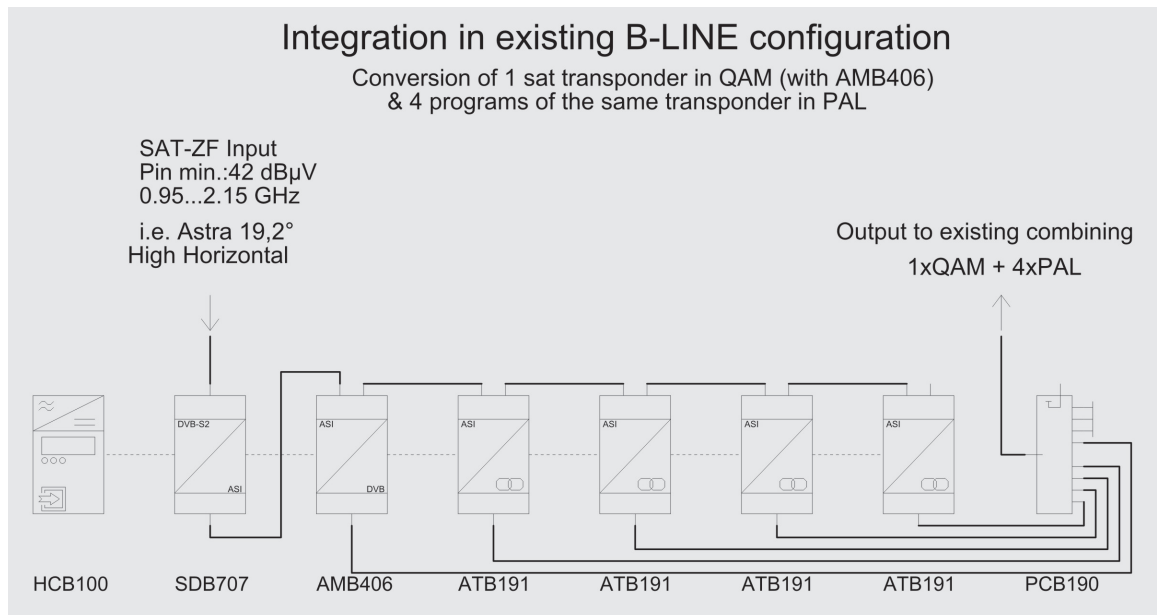

15. Technical data

ASI input

| | |
|--------------|------------------------------|
| Level range | 200 ... 880 mV _{pp} |
| Data rate | 270 Mbps |
| Connector | BNC socket |
| Impedance | 75 Ω |
| ASI polarity | regular/ inverted |

ASI output

| | |
|--------------|-------------------------------|
| Level | 800 mV _{pp} (± 10 %) |
| Data rate | 270 Mbps |
| Connector | BNC socket |
| Impedance | 75 Ω |
| ASI polarity | normal |

ASI signal processing

| | |
|---------------------|-------------------|
| Data rate | 0.625...78 Mbps |
| ASI transfer format | |
| Input | continuous, burst |
| Output | burst |
| TTransfer format | |
| Input | 188, 204 Byte |
| Output | 188, 204 Byte |
| Signal processing | EN 50083-9 [1] |

TV output

| | |
|----------------------------------|---|
| 9848.01/.08/.09: | |
| TV standard | B/G |
| Sound carrier frequencies | 5.5 / 5.742 MHz above pic.carr. |
| 9848.21/.25/.29: | |
| TV standard | D/K |
| Sound carrier frequencies | 6.5 / 6.25 MHz above pic.carr. |
| 9848.22/.24/.28: | |
| TV standard | D/K |
| Sound carrier frequencies | 6.5 / 5.742 MHz above pic.carr. |
| Sound type | double carrier FM |
| Sound mode | mono / stereo / dual / auto (PDC controlled) |
| Audio deviation 1 mono – carrier | 30 / 50 kHz |
| Audio deviation 2 mono - carrier | 30 kHz |
| Audio deviation dual sound | 30 kHz |
| Output frequency range | 45 ... 862 MHz |
| Tuning steps | 10 kHz |
| Output level | max. 116 dBµV |
| Range for level adjustment | 0...31.5 dB (0.5 dB steps) |
| Channel allocation | adj.channel compatible |

| | |
|-------------|-----------------------------------|
| Connector | F socket |
| Impedance | 75 Ω |
| Return loss | ≥ 18 dB 45 MHz -1.5 dB/ Octave |

Signal quality

| | |
|--|------------------------|
| Single channel intermodulation | ≥ 66 dB |
| Signal to noise ratio (S/N) | |
| 3rd order | ≥ 60 dB |
| Spurious 45 ... 862 MHz | ≥ 60 dB |
| C/N in channel (BW = 4.8 MHz) | typ. 69 dB |
| C/N (> 25 MHz, distance from centre of channel; BW=4.8 MHz) | typ. 80 dB |
| S/N ratio parallel sound unweighted/ weighted | typ. 62/ 56 dB |
| Output level stability | max.1 dB _{pp} |
| Frequency stability | ± 30 kHz |

Operating parameters

| | |
|--------------------------------------|-----------------------|
| Current / voltage | 12 V (0.2 V)/ 700 mA |
| Residual ripple of supply voltage | ≤ 10 mV _{pp} |

Environmental conditions

| | |
|---------------------------------------|--------------------------------|
| Temperature range | -10 ... +55 °C |
| Temperature range for data keeping | 5 ... 45 °C |
| Relative humidity | ≤ 80 % (non condensing) |
| Method of mounting | vertical |
| Location of mounting | splash-proof and drip-proof |

Physical information

| | |
|------------------------|-------------------|
| Dimensions (l x w x h) | |
| without 19" - adapter | 50 x 276 x 148 mm |
| with 19" - adapter | 50 x 301 x 148 mm |
| Weight | 1,300 g |

Delivery content

| |
|-------------------|
| 1 x BUS connector |
|-------------------|

Software options

| | |
|-----------------|-------------------|
| Test lines | CKB 101 (9650.51) |
| Subtitling | CKB 102 (9650.52) |
| BISS decryption | CKB 104 (9650.54) |

16. Glossary

| | |
|-------|---|
| AM | Amplitude modulation |
| AP | Anschlussplatte (Terminals board) |
| ASI | Asynchronous Serial Interface |
| ATV | Analogue Television |
| AV | Audio/Video |
| BISS | Basic Interoperable Scrambling System |
| BW | Bandwidth |
| CCIR | Comité Consultatif International des Radiocommunications |
| C/N | Carrier to Noise ratio |
| D/A | Digital-/ Analog- |
| DVB | Digital Video Broadcasting (-C Cable, -S Satellit, -S2 Satellite 2, -T Terrestrial) |
| ETSI | European Telecommunications Standards Institute |
| FIFO | First In – First Out |
| FPGA | Field Programmable Gate Array |
| HF | Hochfrequenz |
| HTML | Hypertext Markup Language |
| HTTP | Hypertext Transfer Protocol |
| I/Q | In-phase/Quadrature-phase |
| ID | Identifier |
| IF | Intermediate Frequency |
| IFI | Intermediate Frequency Interface |
| IIC | Inter-Integrated Circuit (I ² C bus, data bus within device) |
| IP | Internet Protocol |
| LED | Light Emitting Diode |
| MC | Microcontroller |
| MIB | Management Information Base |
| MPEG | Moving Picture Experts Group |
| NIM | Network Interface Module |
| NTSC | National Television Systems Committee* |
| PAL | Phase Alternating Line* |
| PCR | Program Clock Reference |
| PDC | Program Delivery Control |
| PID | Packed Identifier |
| PMT | Program Map Table |
| PLL | Phase-locked loop, |
| RF | Radio Frequency |
| SECAM | Séquentiel couleur à mémoire* |
| SNMP | Simple Network Management Protocol |
| SPI | Serial Peripheral Interface |
| SPTS | Single Program Transport Stream |
| TS | Transport Stream |
| TV | Television |
| VPS | Video Programming System |
| WSS | Wide Screen Signalling |

* colour-encoding systems of analogue television

17. Bibliography

[1] EN 50083-9: Cabled distribution systems for television, sound and interactive multimedia signals, part 9: Interfaces for CATV/SMATV head ends and similar professional equipment for DVB/MPEG-2 transport streams

[2] EN 60728-11: Cable networks for television signals, sound signals and interactive services Part 11: Safety (IEC 60728-11:2005); German version EN 60728-11:2005

[3] RFC 1157 Request for Comments (RFC): RFC Database URL: <http://www.rfc-editor.org/rfc.html>

18. History

| Version | Date | Modification | Author |
|---------|------------|--------------------------|--------|
| 1.00 | 18.07.2008 | basic document | Poch |
| 1.01 | 26.02.2009 | revision (BISS, options) | Häußer |

Options and other TV standards available upon request! Changes due to technical progress possible!

CE Declaration of Conformity

The Manufacturer

BLANKOM Antennentechnik GmbH · Hermann-Petersilge-Str. 1 · 07422 Bad Blankenburg · Germany

herewith declares the conformity of the product group

Product name: ASI - Transmodulator

Type: ATB 19x

Product number: 9848.xx

according to the following regulations

EN 50083-2

EN 60728-11 (as far as relevant)

and additional device-specific regulations, enclosed above, which these products are subjected to.

Datum: 25.02.2009

Unterschrift:



(Geschäftsführer)