

TTB 5x1

DVB - T - TV - TRANSMODULATOR
DVB - T CABLE - TV (analogue)

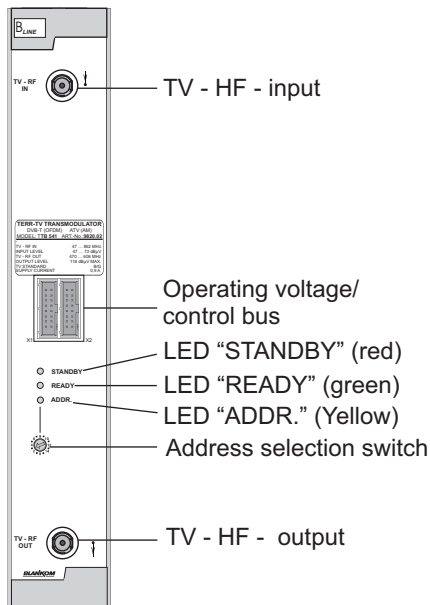

Fig. 01

PRODUCT VARIANTS

| | | | | |
|---------|---------|---------|---------|------------------|
| TTB 511 | 9826.04 | DVB - T | VHF I | [E02 ... E04] |
| TTB 521 | 9827.04 | DVB - T | VHF II | [75 ... 100 MHz] |
| TTB 531 | 9822.04 | DVB - T | VHF III | [E05 ... E12] |
| TTB 541 | 9820.04 | DVB - T | UHF IV | [21 ... 37] |
| TTB 551 | 9821.04 | DVB - T | UHF V | [38 ... 69] |
| TTB 561 | 9823.04 | DVB - T | USB | [S02 ... S10] |
| TTB 571 | 9824.04 | DVB - T | OSB | [S11 ... S20] |
| TTB 581 | 9825.04 | DVB - T | ESB | [S21 ... S41] |

GENERAL

The terrestrial tv - transmodulators TTB 5x1 are components of the headend system B - Line which is conceived for middle sized networks. The modules convert DVB - T - signals into analogue cable - tv - signals.

All modules are programmed at the central control unit and are working independantly afterwards. The status of the individual modules will be displayed by a colored LED.

| | | |
|--------|-----------|-----------------------|
| Red | - STANDBY | Stand by |
| Green | - READY | Operating status |
| Yellow | - ADDR. | Remote control access |

FUNCTION DESCRIPTION

The digital terrestrial signal (transponder) will be transported to the tuner in which it will be selected and demodulated into the transport stream level. The following MPEG - decoder selects a program out of this and delivers an analogue video- and a digital audio - signal which will be converted into two analogue audio - channels within the D/A - converter.

The analogue signals will be transported to separate modulators and summed up within the IF - range. After the following IF - filtration the conversion into the required output - channel takes place. Every module is equipped with a range filter at the output (8 product variants) to minimize the noise storage at the interconnection. The output - channel within the respected range is free selectable. All modules are adjacent channel suitable and produce standard mono / stereo -

Die Baugruppen sind nachbarkanaltauglich und erzeugen normgerechte Mono / Stereo - dual tone signals.

Additional functions : Group delay - correction (by factory)

Software HCB 100: ab V 1.31

PROGRAMMING

| | |
|--------------------------|----------------------|
| Start - TTB 5x1 | |
| Program name | |
| TV - INPUT | |
| Frequency | 47000 ... 860000 kHz |
| Bandwidth | 7 / 8 MHz |
| Spectrum - Inversion | ON / OF |
| Program selection | |
| Service ID | 0 ... 65535 |
| Voice number | |
| Teletext page | |
| TV - Norm | PAL/SECAM/NTSC |
| TV - sound | |
| Audio - level | +3 ... -20 |
| Sound carrier | 1 |
| Frequency | 5,0 ... 9,0 MHz |
| Sound carrier 2 OFF | Sound carrier 2 ON |
| Audio Mode | Audio Mode |
| Mono L/Mono R+L | VPS |
| Mono/Stereo/DUAL | |
| VPS | |
| Output | |
| Frequency | 47000 ... 862000 kHz |
| Output attenuation | 0 ... -20 dB |
| Device status | |
| End - TTB 5X1 | |

Fig. 02

Adjustment with the head end controller

Adjustment of the addresses at the bus extender BEB 100 and at the modules

Activation of the programming mode of each module by selecting the line (BEB 100) and the module position (01... 15) at the head end controller(HCB 100)

yellow LED will be lit up til the beginning of the parameter adjustment

Adjustment of the UCB 1x6 parameter(see fig.02)

green LED is lit up

After the programming the UCB 1x6 will be automatically switched into the operating status

yellow LED lights up briefly / green LED is lit up

Adjustment with the PC / Laptop

Condition for the remote programming is an "online - connection" after IP - standard and an ethernet connection at the PC / Laptop

Adjustment of the line / position addresses at the bus extender BEB 100 as well as at the modules

At the head end controller HCB 100 IP - address input

(e.g. 192.168.001.001)

For "direct connection" between a PC and HCB 100 use a crossed patch cable (RJ 45)

For connection over a deviation use an uncrossed patch cable

HTML - browser start-up and put in IP - address as target address

If connected correctly the HTML - control surface at the PC will open up and a green LED (LINK) at the HCB 100 will be lit up

All adjustment of the modules are specified at the control surface

The manual instructions of the head end controller HCB 100 and the bus extender BEB 100 have to be considered!

TECHNICAL DATAS

VHF/UHF - Input

| | |
|-------------------|----------------------|
| Frequency - range | 47 ... 862 MHz |
| Frequency - grid | 62,5 kHz |
| AFC - range | 90 kHz |
| AGC - level range | 57 ... 83 dB μ V |
| Connector | F - Buchse |
| Impedance | 75 |

OFDM - Demodulator

| | |
|-------------------|---------------------------------|
| Carrier mode | 2 k; 8 k |
| Code - rate | 1/2; 2/3; 3/4; 4/5; 5/6; 7/8 |
| Modulation | QPSK; 16 QAM; 64 QAM |
| Signal processing | En300744 (DVB-T) |

TV - Output

| | |
|--------------------------|--|
| TV - standard | B/G - PAL |
| Output - frequency range | 45 ... 862 MHz (8 product variants) |
| Frequency grid | 50 kHz |
| Output - level | max. 116 dB μ V |
| Level adjusting range | -20 dB (0,5 dB Schritte) |
| Connector | F - Buchse |

Operating parameters

| | |
|-------------------|-------------------------|
| Voltage / Current | 12 V (0,2 V) / 900 mA |
|-------------------|-------------------------|

Environmental conditions

| | |
|-------------------|---------------------------------------|
| Temperature range | -10 ... +55 °C |
| Relative humidity | 80 % (nicht kondens.) |
| Mounting method | senkrecht |
| Mounting location | spritz- und tropfwasser- geschützt |

Additional

| | |
|-----------------------|-------------------|
| Dimensions (l x wx h) | |
| With 19" - Adapter | 50 x 276 x 148 mm |
| With 19" - Adapter | 50 x 301 x 148 mm |
| Weight | 1.543 g |

Delivery contents

1 x Bus connector

Frequency range / channels

| | | |
|---------|-----------------|---------------|
| VHF I | 45 ... 75 MHz | [E02 ... E04] |
| VHF II | 75 ... 100 MHz | |
| VHF III | 174 ... 230 MHz | [E05 ... E12] |
| UHF IV | 470 ... 606 MHz | [21 ... 37] |
| UHF V | 606 ... 862 MHz | [38 ... 69] |
| USB | 100 ... 174 MHz | [S02 ... S10] |
| OSB | 230 ... 300 MHz | [S11 ... S20] |
| ESB | 300 ... 470 MHz | [S21 ... S41] |

HEAD END BUS STRUCTURE

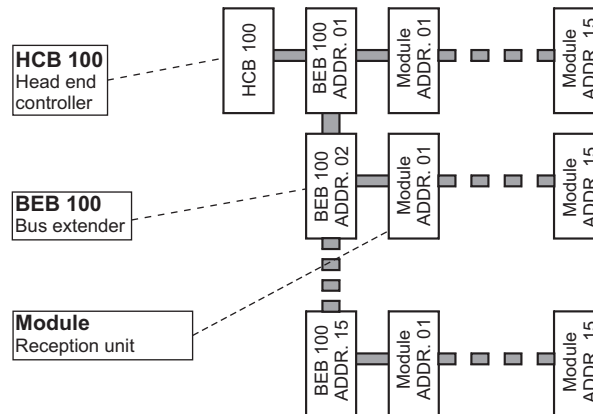

The number of the possible module connections (00 ... 15) to a BEB 100 depends on the total power consumption of this line!

Fig. 03

SECURITY AND OPERATING INSTRUCTIONS

STOP When assembling, starting-up and adjusting the modules, it is necessary to consider the system specific references in the manual instruction!

- ⚠ The modules may only be installed and started up by authorized technical personnel!
- ⚠ When assembling the modules into the receiving points, the adherence of the EMV regulations is to be secured!
- ⚠ The assembly and wiring have to be done without voltage!
- ⚠ All active modules may only be operated with the head end controller HCB 100 or bus extender BEB 100!
- ⚠ The main voltage for all power supply units is 230 V, 50 Hz.
- ⚠ With all work the defaults of the DIN EN 50083 have to be considered!
- ⚠ Especially the safety relevant execution of the DIN EN 50083/1 is necessary!



Options and other TV standards available upon request!