

VMB 191

AUDIO/VIDEO - MODULATOR
A/V IFI ATV (AM) Standard B/G

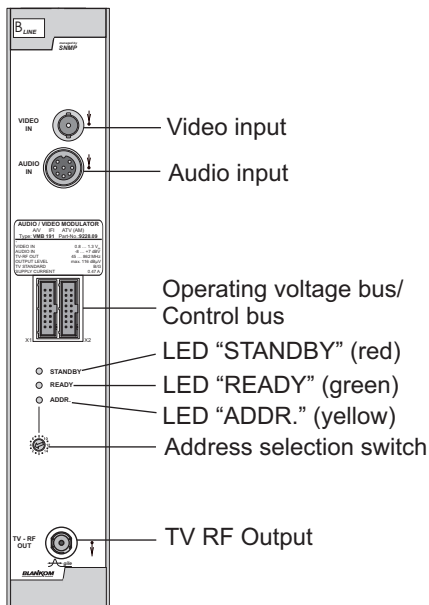

Pic. 01

DEVICE VARIANTS

VMB 191 9228.09 A/V VHF I/ UHF V [45 ... 862 MHz]

Minimum software required for HCB 100 (Headend Controller):

9650.03: Version 2.30
9650.04/ 05: Version 3.11

GENERAL

The agile Audio/Video Modulator VMB 191 is a module of the B-LINE headend system which is conceived as a complete system for middle sized distribution networks.

The module generates an analog cable-TV signal (45...862 MHz) at the output. All modules are programmed at the central control unit (HCB 100) and are working independently afterwards.

The status of the module is displayed via LEDs:

Red	- STANDBY	Standby mode (flashing - Output level- or Bus Error)
Green	- READY	Operating mode
Yellow	- ADDR.	Remote access mode

FUNCTION DESCRIPTION

The video processing contains a Video low pass, a clamping circuit and a video AGC. The audio processing contains a symmetrical input amplifier, a level controller and a stereo- / dual tone-coder. The dataline decoder controls (at "Automatic" mode) the audio operation mode according to the content of the VPS data line. The obligatory adjustment of the audio operation modes as well as their remote control via corresponding contacts at the audio sockets also possible (see Table 01). The inputs of the audio amplifier can also be adjusted unsymmetrically. For it an electronic switch connects the contacts 4 and 5 of the audio socket internally with earth (Pic. 04). The analog video and audio signals will be fed to separate modulators and summed up within the IF range. The conversion into the desired RF output channel is done after the IF filtering. The implementation of high performance mixers and Fractional-N Frequency Synthesizers assure a high transmission quality. The output channel can be adjusted within the range of 45...862 MHz. The modulator VMB 191 is adjacent channel sufficient at the output. The measurement of the reference level is done after each adjustment/programming of the level and frequency values if an input signal exists (at earliest after 100 seconds after system start). In case of an alternating output impedance the module notifies a level error (red led is flashing / Trap - message will be send)

SNMP - Trap message: Bus Error Level Error PLL Error

PROGRAMMING

Start - VMB 191	
Program name	
Output	
Frequency	45000...862000 kHz
Attenuation	0...31.5 dB
TV sound	
Sound carrier 2 Off	Sound carrier 2 On
Sound deviation	Sound deviation
30/50 kHz	30 kHz
Audio adjustments	
Audio impedance	600/12000 Ohm
Audio signal	balanced./unbalanced
Audio level	-8...+7 dBV
Audio mode	
Mono L/ Mono L+R/ Auto(VPS)/ External	Mono/ Stereo/ Dual/ Auto(VPS)/ External
Video adjustments	
Video low pass	On/Off
Video clamping	Soft/Hard
Video control	On/Off
Module adjustments	
Operating status	On/Off
Level control/monitoring	On/Off
End - VMB 191	

Pic. 02

Adjustment with the Headend Controller

Adjustment of the addresses at the Bus Extender BEB 100 and at the modules

Activation of the programming mode of each module by selecting the line (BEB 100) and the module position (01... 15) at the Headend Controller(HCB 100)

yellow LED will be lit up til the beginning of the parameter adjustment

Adjustment of the VMB 191 parameter (see Pic.02)

green LED is lit up

After the programming the VMB 191 will be automatically switched into the operating status

yellow LED lights up briefly / green LED is lit up

Adjustment with the PC / Laptop

Condition for the remote programming is an "online - connection"

after IP - standard and an ethernet connection at the PC / Laptop

Adjustment of the line / position addresses at the Bus Extender BEB 100 as well as at the modules

At the Headend Controller HCB 100 IP - address input (e.g. 192.168.001.001)

For "direct connection" between a PC and HCB 100 use a crossed patch cable (RJ 45)

For connection over a deviation use an uncrossed patch cable

HTML - browser start-up and put in IP - address as target address

If connected correctly the HTML - control surface at the PC will open up and a blue LED (LINK) at the HCB 100 will be lit up

All adjustment of the modules are specified at the control surface

The manual instructions of the Headend Controller HCB 100 and the Bus Extender BEB 100 have to be considered!

TECHNICAL DATAS

Video input

Input voltage with AGC	0.8 ... 1.3 V _{ss}
Input voltage without AGC	1 V _{ss}
Impedance	75
Connectors	BNC socket
Input filter (disconnectable)	5 MHz lowpass
Clamping (switchable)	soft/ hard
AGC	disconnectable

Audio input

Input level	-8 ... +7 dBV
Input resistance (switchable)	0.6 / 12 k
Connector	8-poles according to DIN 45326 (IEC 130 - 9 - 20)
Configuration (switchable)	balanced/ unbalanced

TV output

TV standard	B/G
Sound procedure	FM-dual carrier processing
Sound carrier frequencies	5.5 / 5.742 MHz (above picture carrier)
Sound operation modes	mono / stereo / dual / auto / external
Sound deviation 1 mono - carrier	30 / 50 kHz
Sound deviation 2 mono - carrier	30 kHz
Sound deviation dual tone	30 kHz
Output frequency range	45 ... 862 MHz
Tuning grid	10 kHz
Output level	max. 116 dB μ V
Level adjustment range	0 ... 31.5 dB (0.5 dB-steps)
Channel allocation	adjacent channel sufficient
Connector	F socket
Impedance	75
Return loss	18 dB 45 MHz -1.5 dB/ Octave

Signal quality

Single channel intermodulation	66 dB
Noise level 3rd order	60 dB
Spurious 45...862 MHz	60 dB
C/N within channel (BW = 4.8 MHz)	typ. 69 dB
C/N > 25 MHz within channel (BW = 4.8 MHz)	typ. 80 dB

Parallel sound noise ratio

weighted/ unweighted	typ. 68/ 59 dB
Frequency stability	30 kHz
Output level stability	max. 1 dB _{pp}

Operating parameter

Voltage/ current	12 V (0.2 V) / 470 mA
Residual ripple of the supply voltage	10 mV _{ss}

Environmental conditions

Temperature range	- 10 ... + 55 °C
Temperature range for data keeping	5 ... + 45 °C
Relative humidity	80 % (not condens.)
Mounting method	vertical
Mounting location	squirting and dripping water protected

Physical information

Dimension (l x w x h)	
without 19" adapter	50 x 276 x 148 mm
with 19" adapter	50 x 301 x 148 mm
Weight	1,250 g

Delivery content

1 x BUS connector
1 x SMA connection cable
1 x Specification IF Interface

HEADEND BUS STRUCTURE

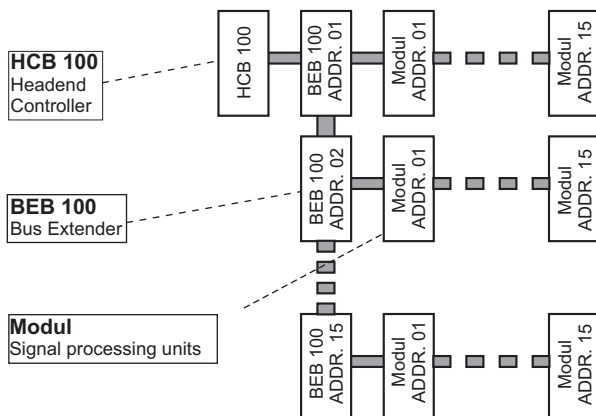

The number of the possible module connections (00 ... 15) to a BEB 100 depends on the total power consumption of this line!

Pic. 03

AUDIO - SOCKET

Allocation

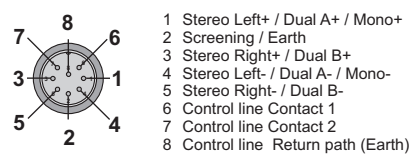

Pic. 04

"External" - Control

MONO	Pins 6 / 8: Connection open	Pins 7 / 8: Connection closed
STEREO	Pins 6 / 8: Connection closed	Pins 7 / 8: Connection open
DUAL	Pins 6 / 8: Connection closed	Pins 7 / 8: Connection closed
	or	
	Pins 6 / 8: Connection open	Pins 7 / 8: Connection open

Tab. 01

SECURITY AND OPERATING INSTRUCTIONS

STOP When assembling, starting-up and adjusting the modules, it is necessary to consider the system specific references in the manual instruction!

- ⚠** The modules may only be installed and started up by authorized technical personnel!
- ⚠** When assembling the modules into the receiving points, the adherence of the EMV regulations is to be secured!
- ⚠** The assembly and wiring have to be done without voltage!
- ⚠** All active modules may only be operated with the Headend Controller HCB 100 or Bus Extender BEB 100!
- ⚠** The supply voltage and operating voltage for all modules operated with direct current has to be in accordance to the technical specifications of the respective module (see respective device manual)!
- ⚠** With all work the defaults of the DIN EN 50083 have to be considered!
Especially the safety relevant execution of the DIN EN 50083/1 is necessary!



Options and other TV standards available upon request!

Changes due to technical progress possible.

Art. - Nr: 9228.09

BLANKOM Antennentechnik GmbH

Hermann - Petersilge - Str. 1 07422 Bad Blankenburg Germany Phone +49 (0) 36741/ 60-0 Fax +49 (0) 36741/ 60-100

IF INTERFACE

IFI 9xxx.x9

IF INTERFACE (ANALOG TV)

X IFI ATV (AM)



VIEW (Module back side)

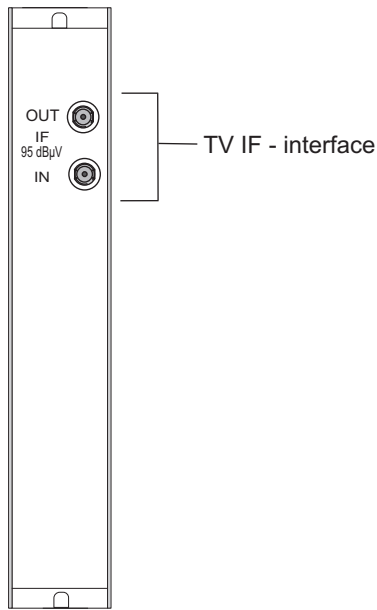

Pic. 01

PRODUCT VARIANTS

STB 1xx	920x.x9	ATV (FM)	IFI	ATV (AM) [45...864 MHz]*)
STB 1xx	921x.x9	ATV (FM)	DI / IFI	ATV (AM) [45...864 MHz]*)
STB 2xx	981x.x9	DVB - S	IFI	ATV (AM) [45...864 MHz]*)
TCB xxx	92xx.x9	ATV (AM)	IFI	ATV (AM) [45...864 MHz]*)
CCB 1xx	923x.x9	ATV (AM)	IFI	ATV (AM) [45...864 MHz]*)
VMB 1xx	922x.x9	V / A	IFI	ATV (AM) [45...864 MHz]*)
VMB 1x2	922x.28	V / A	IFI	ATV (AM) [45...864 MHz]*)

*) 8 subranges each (Standards B/G, D/K, M)

GENERAL

The IF interface is an optional additional function/equipment for the modules of the headend system B - LINE, which is conceived as a complete system for middle sized distribution networks.

The IF - interface separates the internal analogue TV- IF - signal - path and enables the lead out, the external processing and the re-feeding of the IF- signal into the module.

The connection sockets (type SMA) are located at the backside of the individual modules.

The impedance is 75 Ohm.

FUNCTION DESCRIPTION

The analog TV - IF - signal (image and sound carrier) will be split after the main selection (SAW filter) and transported to the IF - output socket.

The processed signal will go from the IF - input socket over a absorption- and adjustment unit directly to the upward mixer.

It has to be considered, that no other channel selective filter stages are located in the input signal path and no level adjustments and/or level control possibilities are available.

For the normal function of the interface, the conditions defined in the manual instructions have to be considered!

SOCKET ALLOCATION (Module back side)

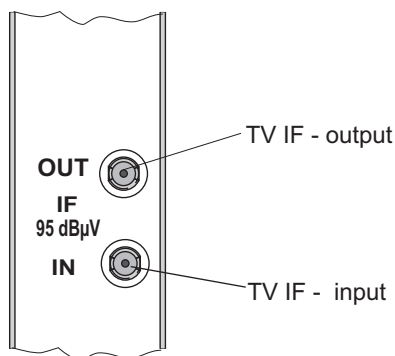

Pic. 02

OPERATING INSTRUCTIONS

1. The IF - input level may only vary ± 1 dB from the IF - output level (95 dB μ V).
External IF - modules may not change the level of the signal and/or have to have the necessary level at the output!
2. The external IF - module, which is used for the processing and/or feeding of the IF - signal, may not produce any counter shafts, which fall below the necessary signal-to-noise ratio (>60 dB).
If necessary, an extra IF - filter has to be connected between the output of the external module and the IF - interface input.
3. If a module with IF - interface is assembled to the wall, the usage of SMA angle plugs for the interface side of the connection cable is recommended.
The cables have to be screwed onto the interface socket before installing the module.
4. The connection cables and the plug connectors for the external IF - modules, as well as their IF - connections have to have an impedance of 75 ohm (e.g. RG 179 B/U with 75 ohm - BNC - plug connections).
5. To bypass the IF - interfaces, the interface sockets have to be connected with a short cable (jumper).

An internal module bypass (e.g. a link plug) is not allowed!

TECHNICAL DATA

Output input frequency (image carrier with analog TV)	38,9 MHz (B/G; D/K) 45,75 MHz (M)
Frequency range	32,15 ... 40,15 MHz (B/G; D/K) 41 ... 47 MHz (M)
Output- / input level	95 dB μ V
Impedance	75 Ohm
Connector	2 x SMA socket

APPLICATION SAMPLES

1. Additional NICAM sound carrier

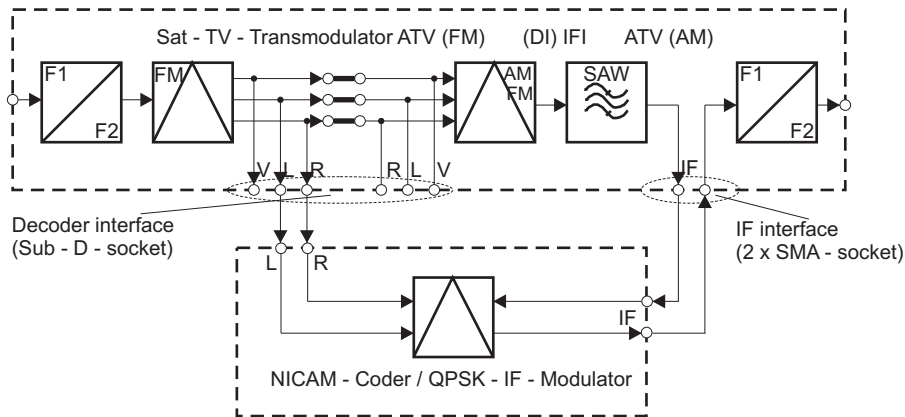

Pic. 03

2. Additional IF selection

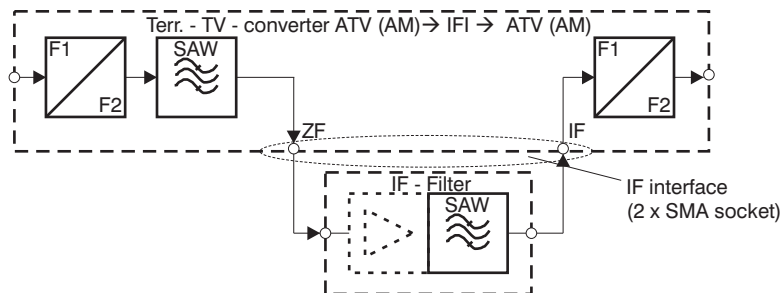

Pic. 04

SECURITY AND OPERATING INSTRUCTIONS

- STOP** When assembling, starting-up and adjusting the modules, it is necessary to consider the system specific references in the manual instruction!
- ⚠** The modules may only be installed and started up by authorized technical personnel!
- ⚠** When assembling the modules into the receiving points, the adherence of the EMV regulations is to be secured!
- ⚠** The assembly and wiring have to be done without voltage!
- ⚠** All active modules may only be operated with the Headend Controller HCB 100 or Bus Extender BEB 100!
- ⚠** The supply voltage and operating voltage for all modules operated with direct current has to be in accordance to the technical specifications of the respective module (see respective device manual)!
- ⚠** With all work the defaults of the DIN EN 50083 have to be considered!
Especially the safety relevant execution of the DIN EN 50083/1 is necessary!



Options and other TV standards available upon request!

Changes due to technical progress possible.

Part. - No: 9xxx.xx

BLANKOM Antennentechnik GmbH

Hermann - Petersilge - Str. 1 07422 Bad Blankenburg Germany Phone +49 (0) 36741/ 60-0 Fax +49 (0) 36741/ 60-100